

APH 6530

HYDROSTATIC VIBRATORY PLATE



CLIMBING AND PERFORMING

The APH 6530 is another powerful worker that delivers compaction force every step of the way. The plate is equipped with the market-leading Ammann three-shaft exciter system, which not only enables performance and climbing ability but also makes the machine more responsive and easier to handle for the operator. The AP 6530 weighs in at 491 kg.

TRIPLE-SHAFT EXCITER SYSTEM

- Increases power and compaction forces.
- Keeps plate movement consistent for smooth travel.
- Performs well in heavy, cohesive soils.
- Climbs while backfilling saturated areas.
- Works on sticky ground.

INDUSTRY LEADER

- Unique Ammann triple-shaft exciter system overcomes grades between 30% and 35%.
- Ammann hydraulic plate compactors are the strongest machines in their class.
- Hydraulic pump enables smooth direction changes.

OPTIONAL TECHNOLOGY

- ACE^{econ} continuously measures and monitors the compaction level.

INNOVATIVE HANDLE

- Unique orbital system delivers great control with minimal effort.
- Vibration-isolated to reduce stress on the operator.

DURABLE, EASY TO MAINTAIN

- Best in class in servicability thanks to wide opening service hoods.
- Wear-resistant, self-cleaning base plate.
- Sturdy protection frame with central lifting point.
- Low maintenance costs because of fully hydrostatic drive and vibration.

APPLICATIONS

- Soil / earthwork
- Set paved roads / paving stones
- Trench work
- Road construction
- Foundation work
- Civil engineering
- Landscaping

TECHNICAL SPECIFICATIONS
APH 6530 HYDROSTATIC VIBRATORY PLATE

WEIGHT & DIMENSIONS

MACHINE WEIGHT BASIC UNIT	191 kg (1082 lb)
WITH EXTENSION PLATES 75 MM	515 kg (1135 lb)
WITH EXTENSION PLATES 150 MM	527 kg (1162 lb)
A BASE PLATE LENGTH	470 mm (18.5 in)
B MACHINE LENGTH	930 mm (36.6 in)
C WITH HANDLE	1840 mm (72.4 in)
D MACHINE HEIGHT	870 mm (34.3 in)
E HANDLE HEIGHT (WORK)	1000 mm (39.4 in)
F HANDLE HEIGHT (TRANSPORT)	1500 mm (59.1 in)
G MACHINE WIDTH	550 mm (21.7 in)
WITH EXTENSION PLATES	700/850 mm (27.6/33.5 in)

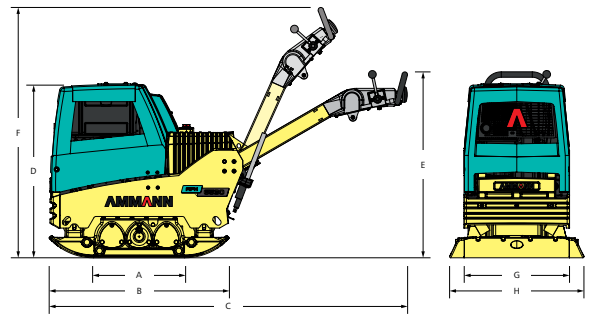

ENGINE

ENGINE	Hatz 1D81S
FUEL	Diesel
ENGINE OUTPUT	13.7 HP / 10.1 kW
AT RPM	3000 rpm
FUEL CONSUMPTION	2.5 l/h (0.6 gal/h)

COMPACTION FORCES

MAX. VIBRATION FREQUENCY	55 Hz (3300 vpm)
MAX. CENTRIFUGAL FORCE	65 kN
WORKING SURFACE BASIC UNIT	1056 m ² /h (11367 ft ² /h)
WITH EXTENSIONS	1344/1632 m ² /h (14467/17567 ft ² /h)
MAX. COMPACTION DEPTH (DEPENDING ON GROUND CONDITIONS)	90 cm (35 in)

MISCELLANEOUS

OPERATING SPEED	32 m/min (1 mph)
TANK CAPACITY	7 l (1.5 gal)
GRADEABILITY	36 %
MAX. INCLINE TO ALL SIDES	30 °



STANDARD EQUIPMENT

- Ammann unique tripple shaft exciter system
- Control handle bar, ergonomically adjustable and lockable
- Orbitrol system providing optimal drive control
- Protective casing: Protects functional components against dirt and damage, offers easy accessibility for service
- Powerful, air cooled and silenced hatz diesel engines with oil alert system and low emission values
- 3 year extended warranty program

OPTIONAL EQUIPMENT

- Extension plates (75 / 150 mm)
- Operation hour meter
- Electric starter and emergency stop
- Compaction control system ACE^{econ}
- Emergency stop at the end of the handle for highest operator safety

For additional product information and services please visit:
www.ammann-group.com

Specifications are subject to change.

MSS-1062-01-EN | © Ammann Group | Images: © www.fotopizza.com

AMMANN